

Microphone Preamp Remoting Kit

Remote Gain Controller
RGC-24A-M w/accessories

User's Manual

(en)

CONTENTS

1.DEVICE OVERVIEW.....	3
1.1.Kit Contents.....	4
2.INTRODUCTION.....	4
2.1.Features.....	4
2.2.Typical application.....	5
3.IMPORTANT SAFETY NOTES.....	6
4.OPERATION.....	6
4.1.Selecting the device address.....	6
4.2.Selecting the preamplifier type.....	6
4.3.Active/passive mode.....	6
4.4.Reset/power cycle behavior.....	6
5.MIDI INTERFACE.....	7
5.1.Testing and Troubleshooting.....	7
6.MODIFICATION OF A BEHRINGER ADA8000.....	8
6.1.Introduction.....	8
6.2.Prerequisites for Modding.....	8
6.3. Preparation.....	9
6.4.Coupler wiring and installation.....	10
6.5.Re-assembling the preamp.....	13
7.ADVANCED TOPICS.....	15
7.1.List of advanced settings.....	15
7.2.Changing advanced settings.....	16
7.3.Preamp requirements for remote gain control.....	17
7.4.Matching the control curve to your preamp.....	17
7.5.Reset to Factory Defaults.....	17
8.SPECIFICATIONS.....	18
9.APPENDIX.....	19
9.1.Warranty.....	19
9.2.Contact.....	19
9.3.Recycling.....	19
9.4.About this document.....	19

1. DEVICE OVERVIEW



Element	Function	
"ACTIVE" LED	On when the controller is active (gain control is enabled), off when the controller is inactive. If a valid MIDI command is detected, the light goes dark for a moment to indicate reception.	
"ACTIVE" Button	Press to toggle between active and inactive mode. To perform "factory defaults reset", press and hold down while connecting power until the "ACTIVE" LED flashes three times.	
DIP Switch	Switch	Meaning
	1/2	Selects the MIDI channels to which the device responds to: OFF/OFF: Channels 1/2/3 (for preamps 1/2/3) OFF/ON: Channels 4/5/6 (for preamps 1/2/3) ON/OFF: Channels 7/8/9 (for preamps 1/2/3) ON/ON: Channels 10/11/12 (for preamps 1/2/3)
	3/4	Selects the preamp type for PREAMP1, PREAMP2 and PREAMP3: OFF/OFF: Behringer ADA8000 (5k neg. log)
	5/6	OFF/ON: Focusrite OctoPre MkII (25k neg. log) ON/OFF: unused
	7/8	ON/ON:: Digital mode for 5V/500 Ohms Reed relays (e.g. for pad/phantompower switching)
"POWER" LED	On when the device is powered up	
"POWER" Jack	Power input	
"IN" Jack	MIDI Input	
"THRU" Jack	MIDI Thru. All data received on "IN" is passed to "THRU" without modification to allow daisy-chaining of MIDI equipment.	
"PREAMP 1" Jack	To preamp #1 (optocouplers 1-8)	
"PREAMP 2" Jack	To preamp #2 (optocouplers 9-16)	
"PREAMP 3" Jack	To preamp #3 (optocouplers 17-24)	

Table 1: Overview of the device

1.1. Kit Contents

The kit contains everything you need to bring remote gain control to three eight-channel preamps:

- Remote Gain Controller box, model RGC-24A-M
- Power supply 12V, 1A
- 24 high-grade analog optocouplers
- 3 pcs. D-SUB cable, 9 pin, 1:1 male-female (for connecting the preamps to the controller)
- 3 pcs D-SUB connectors, 9 pin, male, for preamp mounting
- 3 pcs. flat ribbon cable, 9 pin, for connecting optocouplers to the D-SUB
- 3 pcs. insulated copper wire, for connecting the common anode of the couplers together
- Green LED for testing purposes
- Cable ties
- This manual

2. INTRODUCTION

2.1. Supported Microphone Preamps

Currently, preamps with 5k or 25k logarithmic potentiometers are supported. Typical models using these values are:

- Behringer ADA8000
- Focusrite OctoPre MkII

Remote switching of digital functions (e.g. pad or phantom power) via reed relays is also supported. The required relays are not included.

2.2. Features

The Microphone Preamp Remoting Kit adds remote gain control capability to your existing preamps, enabling you to position your microphone preamps on stage. Gain control is achieved by paralleling the existing potentiometers with high-class, analog optocouplers driven by an external control box (the Remote Gain Controller). When active, these couplers take over the function of the mechanical potentiometers for gain adjustment. The individual gain levels can be set using standard MIDI commands.

The system has many advantages over other solutions:

- Allows to re-use existing preamps
- One RGC-24A-M controls up to 24 channels (e.g. three eight-channels preamps).
- Can be extended up to four controllers (96 channels)
- Sound quality and characteristics of your preamps remain unchanged
- Very simple installation, needs only two solder points per channel within the preamp
- Non-intrusive mod, can easily be undone
- No further modification of the original circuit
- Preset control curves (gain vs. resistance) for different preamps
- Control curves can be altered by the user for perfect matching to any preamp type
- Modified preamps retain original gain control function
- Full opto-isolation between preamp and control box
- Passive design, does not draw power from the preamp's supply
- Quality product „Made in Switzerland“

2.3. Typical application

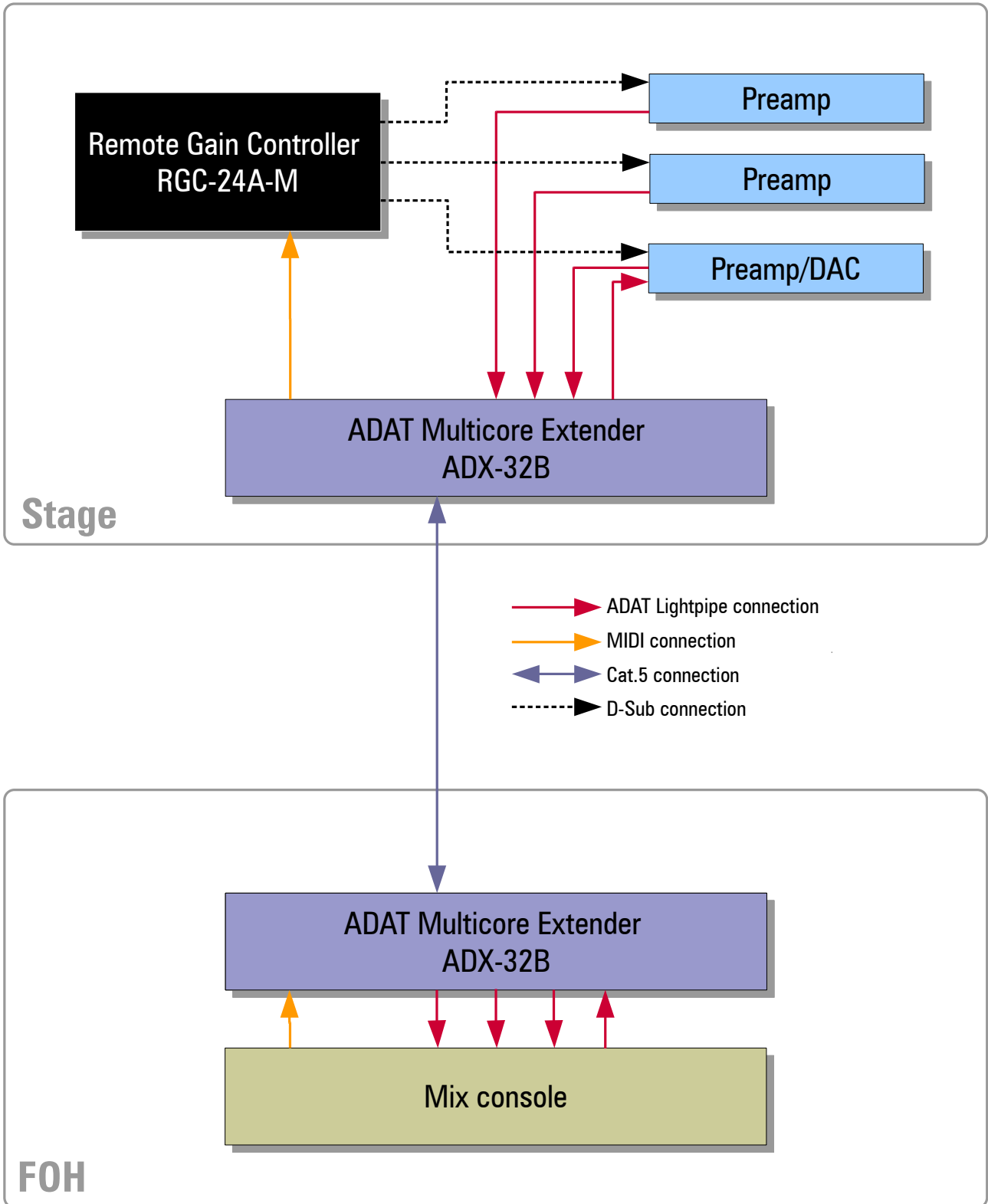

Picture 1: Digital multicore (24/8 configuration) with remote gain control

3. IMPORTANT SAFETY NOTES



- Never connect any other equipment (RS232 etc.) to the D-SUB outputs! The equipment and/or the Remote Gain Controller may get DAMAGED!

Microphone preamplifiers contain parts operating at mains voltage. Only trained persons may open, repair or modify such devices! Observe the following precautions when modifying devices:



- Disconnect the mains cord before opening any microphone preamp
- Make sure not to damage insulating parts
- Make sure newly installed equipment is kept away from internal mains voltage and properly isolated.

4. OPERATION

4.1. Selecting the device address

To allow multiple remote gain controllers on one MIDI port, the device address (= MIDI channels) where the RGC responds to can be altered. Use DIP-Switches 1/2 to set the MIDI channels (see 5. MIDI Interface)

4.2. Selecting the preamplifier type

The RGC supports four different control curves for different types of preamps.. Curve selection is individually for each preamp output, that means that different preamps can be mixed on a single RGC.

DIP "AMP TYPE" setting		Preamp models	Coupler type	Potentiometer mimic	Minimum firmware version *
OFF	OFF	Behringer ADA8000	Silonex NSL32-SR2	5k negative logarithmic	1
OFF	ON	Focusrite OctoPre MkII	Silonex NSL32-SR2	25k negative logarithmic	2
ON	OFF	-	-	-	
ON	ON	-	5V/500 Ohm Reed Relays	Digital mode	2

* See bottom of the device for firmware version. For upgrading, please contact us.

We will continue to add more pre-defined curves on customer request; please contact us with your requirements. The characteristic curves can also be altered by the user via MIDI SYSEX messages. See Chapter 7.1 List of advanced settings for more information on this.

4.3. Active/passive mode

Using the white "ACTIVE" button, the controller can be switched to inactive mode (disabled). All outputs are then switched off, and the couplers reach maximum resistance (several mega-ohms). This makes them appear to the preamp as if they were removed, and gain control can be done traditionally using the preamp's potentiometers.

4.4. Reset/power cycle behavior

All settings, including active/passive mode and gain values, are stored in an internal EEPROM which retains its contents even when power is disconnected. On power up, all settings are restored to their last values.

5. MIDI INTERFACE

5.1. Channel/Controller/Value setup

Gain adjustment is done via standard MIDI control commands:

- The preamp (1, 2 or 3) is selected by the MIDI channel
- The optocoupler (1 to 8) is selected by the controller number
- The gain value is set by adjusting the controller's value

The raw MIDI bytes are indicated in [square brackets]

DIP Address setting		MIDI Channel *	Controller number *	Gain value
OFF	OFF	2 = Preamp 1 [0xB1] 3 = Preamp 2 [0xB2] 4 = Preamp 3 [0xB3]	24 = Optocoupler 1 [0x18] 25 = Optocoupler 2 [0x19] 26 = Optocoupler 3 [0x1A] 27 = Optocoupler 4 [0x1B] 28 = Optocoupler 5 [0x1C] 29 = Optocoupler 6 [0x1D] 30 = Optocoupler 7 [0x1E] 31 = Optocoupler 8 [0x1F]	0...127 [0x00...0x7F] 0 = minimum gain 127 = maximum gain
OFF	ON	5 = Preamp 1 [0xB4] 6 = Preamp 2 [0xB5] 7 = Preamp 3 [0xB6]		
ON	OFF	8 = Preamp 1 [0xB7] 9 = Preamp 2 [0xB8] 10 = Preamp 3 [0xB9]		Resulting gain in dB depends on preamp type, for ADA8000 0...127 means +10..+50dB (approx 0.3dB steps)
ON	ON	11 = Preamp 1 [0xBA] 12 = Preamp 2 [0xBB] 13 = Preamp 3 [0xBC]		

* These values and mappings can further be changed using SYSEX commands (see chapter 7.Advanced Topics).

Examples

(The following examples assume that the "ADDR." DIP switches are both "OFF"):

- To set the gain on preamp 1, channel 1, to 63 (mid-scale):
On MIDI channel 2, set controller number 24 to value 63
[Raw byte sequence: 0xB1 0x18 0x3F]
- To set the gain on preamp 3, channel 8, to 0 (minimum):
On MIDI channel 4, set controller number 31 to value 0
[Raw byte sequence: 0xB3 0x1F 0x00]

5.2. Testing and Troubleshooting

To test if your MIDI controller is configured correctly for the RGC:

- Observe the yellow "ACTIVE" LED while adjusting gain. If a MIDI command to the RGC was recognized, the LED goes dark for a moment to show the command's acceptance.
If the LED remains on, double-check that:
 - MIDI channels match the RGC's configuration (DIP-Switch setting)
 - MIDI controllers match the RGC's expected values
- Use the supplied green LED to test if the controller is actually working. Insert the longer wire (anode) into contact #1 from D-SUB connector on the RGC, and the shorter wire into any of contacts #2 to

#9. The LED should change brightness when gain values change (dark at value 0, fully lit at value 127). Hint: L The pins numbers are printed on the D-SUB jack (very small).

Pin	Function
1	Common Anode
2	Cathode CH2
3	Cathode CH4
4	Cathode CH6
5	Cathode CH8

Pin	Function
6	Cathode CH1
7	Cathode CH3
8	Cathode CH5
9	Cathode CH7

6. MODIFICATION OF A BEHRINGER ADA8000

6.1. Introduction

This model is one of the most popular preamp models which is known as a good value-for-money device, and is very versatile due to its 8-channel A/D and also D/A function. Modding the ADA8000 is a relatively simple job and requires only basic skills (soldering and making a cutout in the rear), and is explained below.

Device internals

For gain control, it uses one potentiometer per channel (5k, neg. logarithmic taper) which allows adjustment in the range of +10dB up to +60dB. The gain pot terminals are easily accessible when the device is opened.

Modded device behavior

The stock gain potentiometer continues to function as before if the remote gain controller is not connected or if it's switched off. To experience remote control magic, turn all knobs to the leftmost (minimum position) and switch on the remote gain controller – now you are able to adjust the gains from everywhere, using common MIDI controllers.

Limitations

- You cannot mix local and remote control, but you can switch between both modes.
- The maximum gain which can be set in remote-control mode is reduced to +50dB due to a limited resistance range of the couplers. This is rarely a problem because these high gain values are seldom used because the ADA8000 gets noisy on the higher gain ranges.

6.2. Prerequisites for Modding

- The contents of this kit
- Philips PH1 screwdriver
- Philips PH2 screwdriver
- Wire cutter
- Solder iron
- Solder wire
- Saw and/or fretsaw, or preferably a mini-grinder tool (e.g. DREMEL or Proxxon with cut-off wheel)
- Small flat file for smoothing of the cutout edges
- 3mm drill
- 5mm wrench
- Bench vise for press-fitting the connector

6.3. Preparation

Step 1: Remove the top cover (6 screws, different sizes!)



Step 2: Remove both rack mount flanges (2x2 screws)

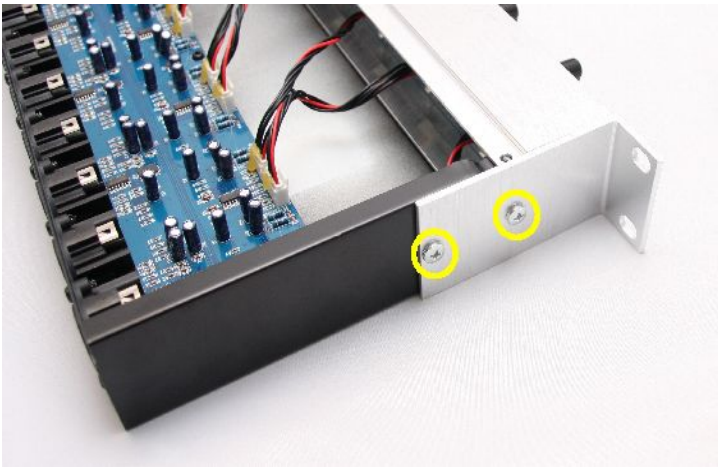

Step 3: Remove 3 screws from the bottom

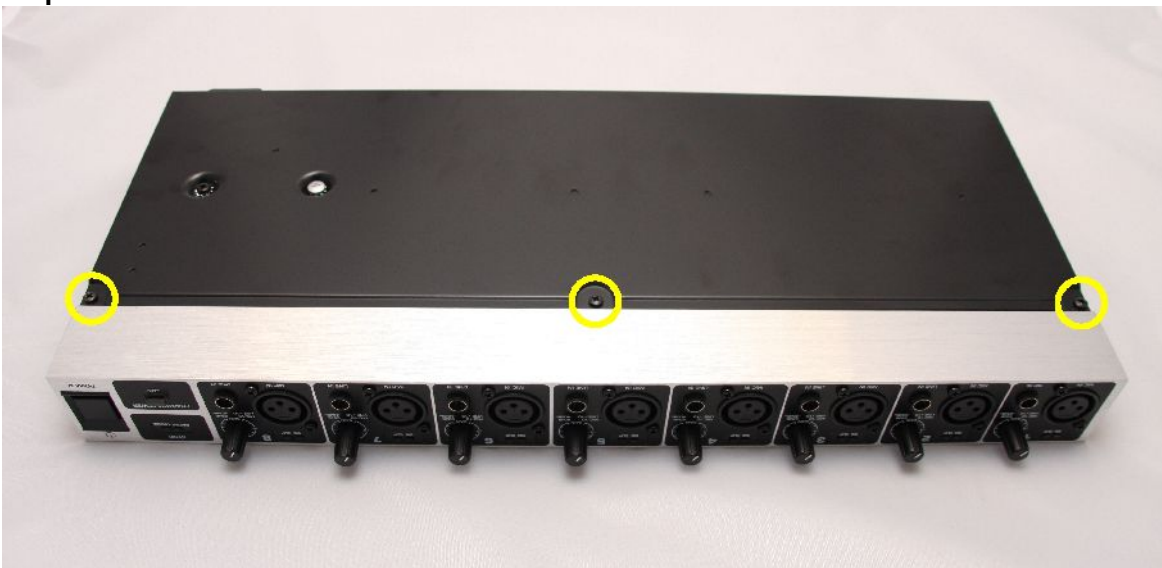

Step 4: Disconnect the 9 cables to the front panel from the main PCB

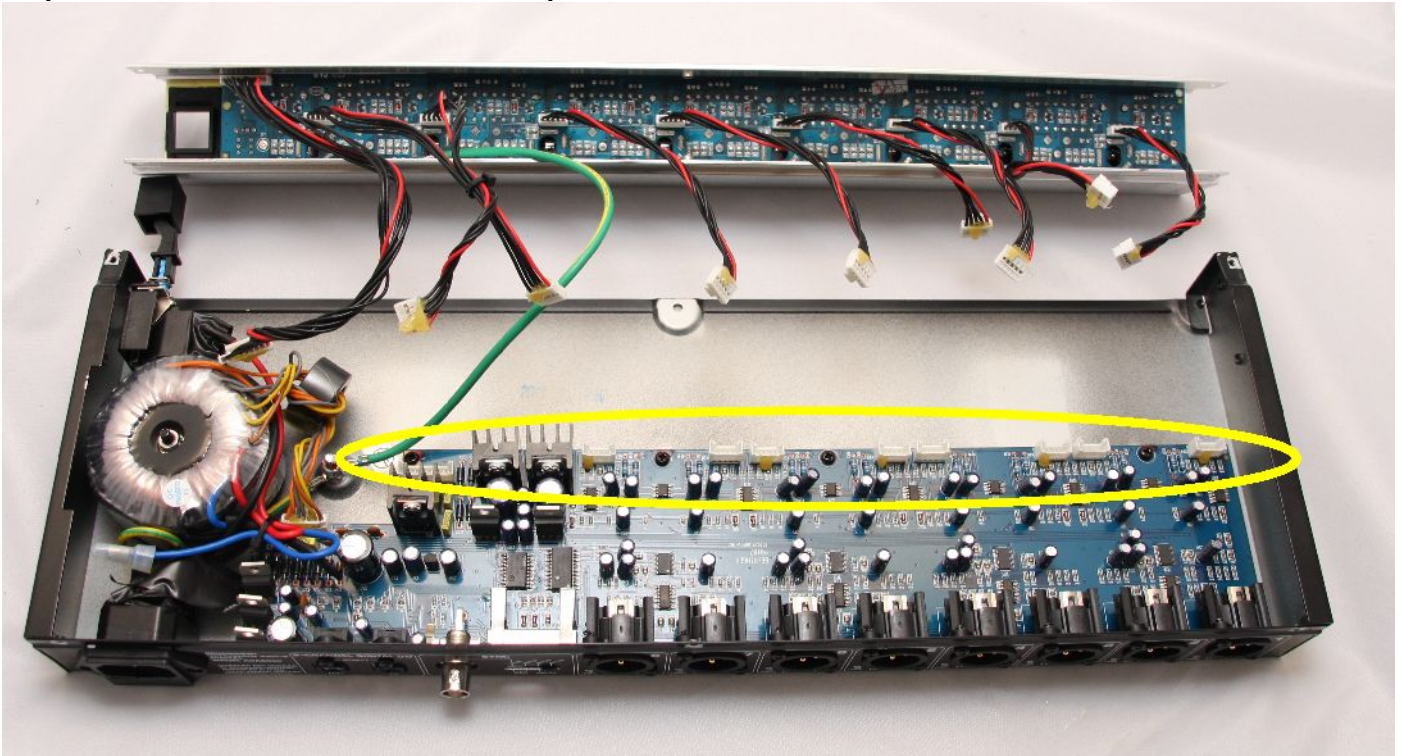

6.4. Coupler wiring and installation

The mod is installed by soldering eight optocouplers parallel to the potentiometers. The input (LED) terminals are wired with ribbon cable to an D-SUB connector. The wiring is according to the diagram in Picture 2.

1. Locate the potentiometer terminal solder points on the front PCB (see pictures 4 and 6)
2. Cut the coupler wires "Ra" and "Rb" to about 20mm length and solder them to the potentiometer terminals (Picture 3, 5, 7).
3. Use the enameled copper wire to connect the anode ("A" terminals) of all couplers together. To remove the insulation and wet them with solder, heat the wire with the solder iron for about 20 seconds at 400°C. (Picture 7) Note: This must be done before connecting the wire to the couplers as they can be damaged by excessive heat.
4. Prepare the ribbon cable: Insert the cable into the D-SUB connector with conductor #1 (red) on Pin 1 of the connector. Pin 1 is upper left when looking at the mating face.
5. Make sure the cable is straightly oriented to the connector before press-fitting the connector (this can be done using a bench vise. Be careful only to apply gentle force in order not to damage the connector).
6. Solder conductor #1 (red) of the ribbon cable to the "A" terminal of coupler at CH1
7. Solder conductor #2 to "C" terminal of coupler at CH1
8. Solder conductors #3...#9 to "C" terminals of couplers at channels CH2...CH8
9. Use cable ties to fix the wires to the anode wire as required.
10. Mark a rectangular area of 20x20 mm (measured from the edge); horizontally centered with the switch (Picture 9)
11. Cut the area using a saw (fretsaw), or a small grinder tool (e.g. DREMEL or Proxxon) with cutting disc.
12. Trim the edges using a file

13. Carefully remove all metal chips and metal dust from the interior of the ADA8000, especially from the PCBs. This can be done using an old toothbrush and a vacuum cleaner.
14. Insert the 9-pin connector and mark the position of the holes (Picture 10)
15. Remove the connector and drill 2 at the marked position (Ø3mm)
16. Mount the connector using the supplied bolts with flat washers on the front, and the spring washers and nuts on the rear (pictures 11 and 12)
17. The ribbon cable may be routed through the capacitors on the mainboard (Picture 14)

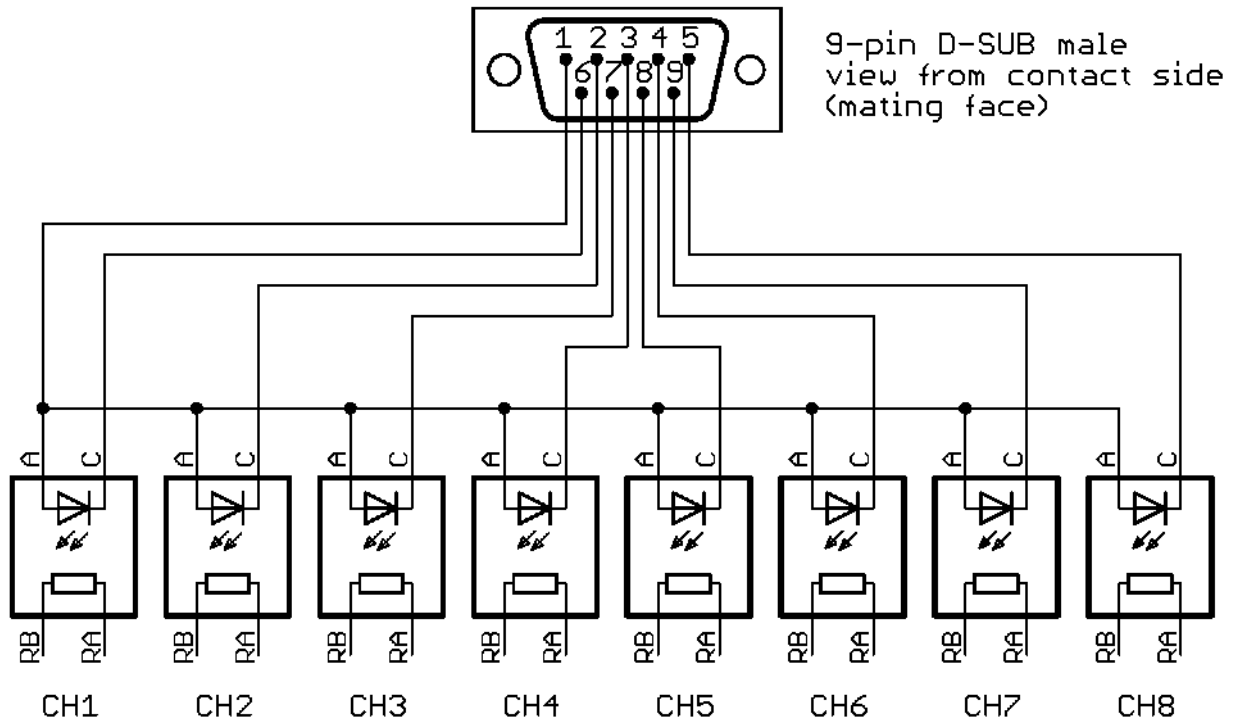

Picture 2: Schematic of internal wiring

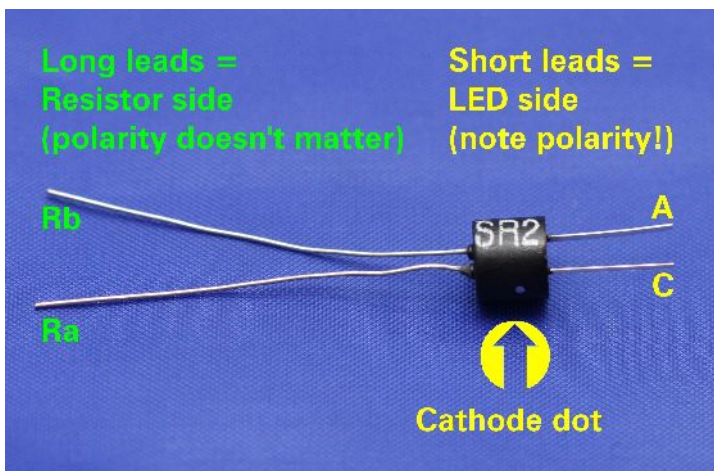

Picture 3: Pinout of Sironex NSL-32SR2

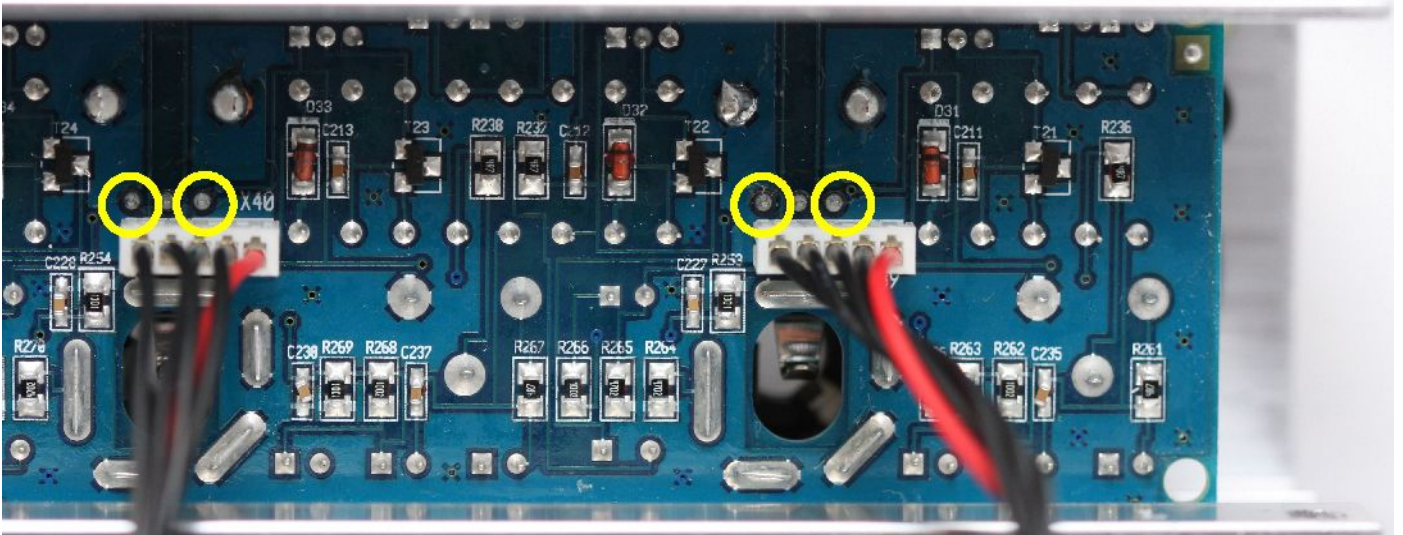

Picture 4: Solder points for couplers

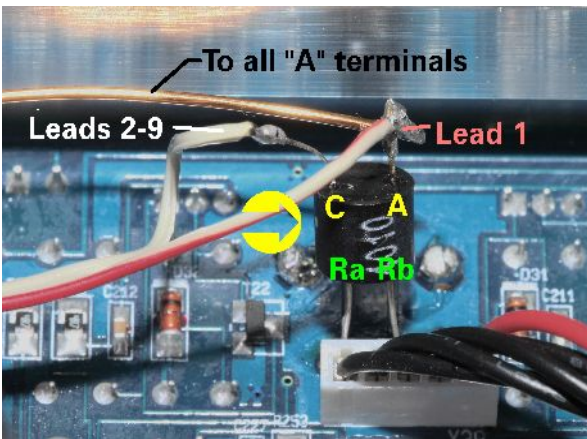

Picture 5: Coupler wiring

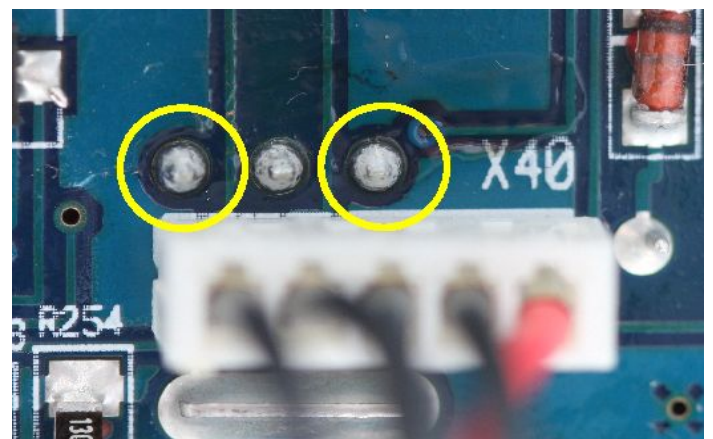

Picture 6: Solder points (closeup)



Picture 7: Couplers with common anode wire soldered



Picture 8: Finished front panel with couplers, anode wire and ribbon cable

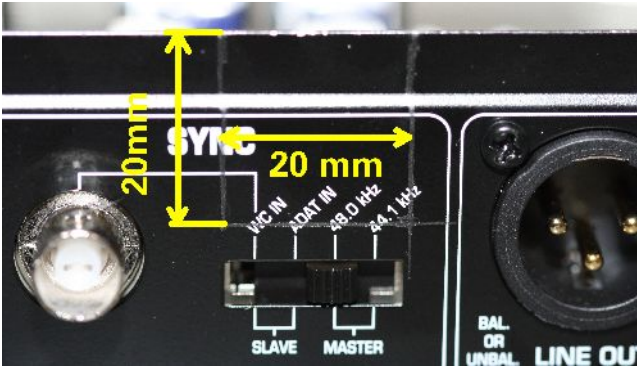

Picture 9: Cutout marking

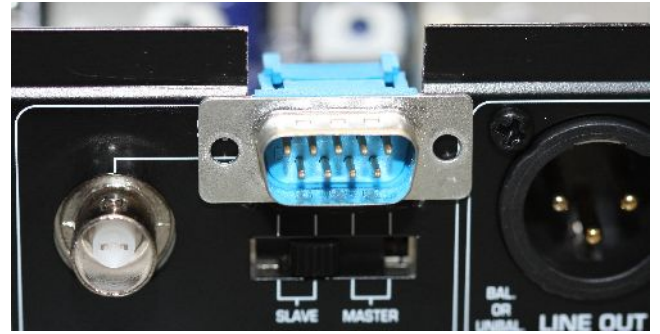

Picture 10: Drill marking

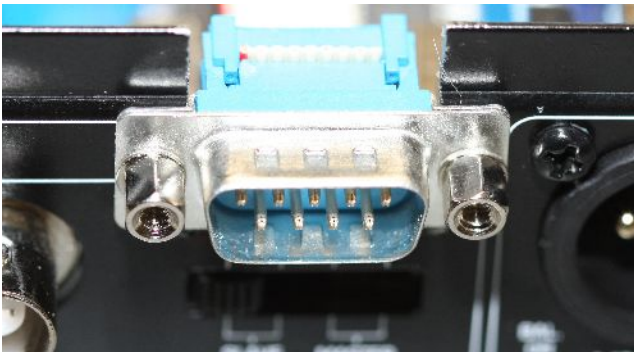

Picture 12: Mounted jack from outside

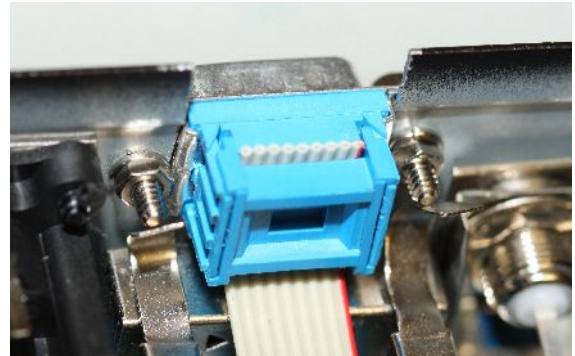

Picture 11: Mounted jack from inside

6.5. Re-assembling the preamp

1. Before re-installing the shield hood, isolate the inner side using PVC electrical tape to avoid short-circuits with the newly installed couplers (Picture 13)
2. Attach the silver front profile to the bottom using 3 larger black screws.
3. Attach both rack mount flanges and screw them to the sides, using 4 silver screws.
4. Slide over the top cover and attach it using 3 smaller black screws on the rear, and 3 larger black screws on the top.

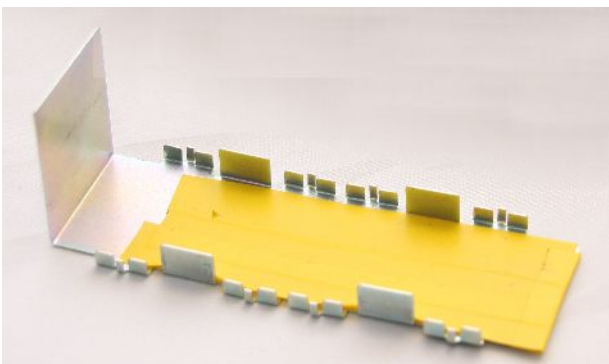

Picture 13: Tape-isolated shield



Picture 14: Interior view with applied mod



Picture 15: Finished!

7. ADVANCED TOPICS

7.1. List of advanced settings

To allow interfacing with almost every MIDI controller, whether in software or hardware, the RGC-24A-M allows fine-grain control of its behavior via "GLOBAL PARAMETERS":

- The MIDI channel to which the RGC responds can be set to any value (0 ...15)
- The MIDI controller numbers on which the gain controls live can be altered to any value (0...127)
- The number of MIDI controllers on each channel can be adjusted. The default of 8 controllers per channel can be altered e.g. to 24 controllers on only one channel.
- The curve characteristics (the mapping between controller value and resistance) can be defined by the user. Each curve is defined by 17 values, dividing the gain entire control range into 16 sections.

Slot	Parameter	Possible values	Default value
00: General Configuration	01: MIDI channel base when DIP-Switches 1/2 are set to OFF/OFF	0x00 ...0x0F	0x01 (= Channels 2,3,4)
	02: MIDI channel base when DIP-Switches 1/2 are set to OFF/ON	0x00 ... 0x0F	0x04 (= Channels 5,6,7)
	03: MIDI channel base when DIP-Switches 1/2 are set to ON/OFF	0x00 ... 0x0F	0x07 (= Channels 8,9,10)
	04: MIDI channel base when DIP-Switches 1/2 are set to ON/ON	0x00 ... 0x0F	0x0A (= Channels 11,12,13)
	05: MIDI controller base	0 ...127 (0x00 ... 0x7F)	0x18 (= Controllers 24...31)
	06: Number of controllers per MIDI channel	0x00 ... 0x18	0x08
01: Curve adjustment for curve #1	00 ... 16: Curve node index	0x000 ... 0x3FF (0 ... 1024)	
02: Curve adjustment for curve #2	00 ... 16: Curve node index	0x000 ... 0x3FF (0 ... 1024)	
03: Curve adjustment for curve #3	00 ... 16: Curve node index	0x000 ... 0x3FF (0 ... 1024)	
04: Curve adjustment for curve #4	00 ... 16: Curve node index	0x000 ... 0x3FF (0 ... 1024)	

Table 2: List of Global Parameters

7.2. Changing advanced settings

This is done according to the “General MIDI” (GM1) standard, using the message “GLOBAL PARAMETER CONTROL”. This message is defined as follows:

Byte value	F0	7F	<Address>	04	05	01	01	02
Meaning	Universal RealTime SysEx header			DEVICE CONTROL	GLOBAL PARAMETER CONTROL	Slot Path Length	Parameter ID Width	Value Width
Remarks			Set according to DIP					

Byte value	00	<Slot>	<Param ID>	<Value LSB>	<Value MSB>	[<Param ID>]	[<Value LSB>]	[<Value MSB>]
Meaning	Slot Number MSB	Slot Number LSB	Parameter ID	Value lowest 7 bits	Value highest 7 bits	Parameter ID	Value lowest 7 bits	Value highest 7 bits
Remarks		See Table 3	See Table 3					

Byte value	[<Param ID>]	[<Value LSB>]	[<Value MSB>]	F7
Meaning							End of SYSEX message
Remarks							

If the command is accepted, the “ACTIVE” LED goes dark for a moment.

Example 1:

To change the behavior in such a way that all three preamps are on MIDI channel 5, mapped to controller numbers 64 to 88, we need to adjust the settings in slot 00.

We assume that DIP-Switches 1/2 are OFF/OFF, and the device has its default configuration of MIDI base channel 0x01.

- set the MIDI channel base (parameter 01) to 0x04 (the channel base is the number of the first MIDI channel minus 1)
- the controller number base (parameter 05) to 0x40
- the number of controllers per channel (parameter 06) to 24 (0x18):

F0 7F 01 04 05 01 01 02 00 00 01 04 00 05 40 00 06 18 00 F7

Note that the MIDI channel where the controller responds to has been altered. The new MIDI channel becomes effective after power is cycled. Subsequent commands then need to start with F0 7F 05.

Example 2:

We assume that DIP-Switches 1/2 are OFF/OFF, and the device has its default configuration of MIDI base channel 01.

To adjust curve #2 (example: 5k neg log, using Silonex NSL-32SR2) with y-values of

0, 1, 2, 3, 5, 8, 11, 16, 21, 35, 51, 75, 114, 181, 299, 520, 1023

execute

F0 7F 01 04 05 01 01 02 00 02 00 00 00 01 01 00 02 02 00 03 03 00 04 05 00 05 08 00 06 0B 00 07 10 00 08 15 00 09 23 00 0A 33 00 0B 4B 00 0C 72 00 0D 35 01 0E 2B 02 0F 08 04 10 7F 07 F7

7.3. Preamp requirements for remote gain control

The controller can be adjusted to function with nearly every microphone preamp, if it meets the following conditions:

- The original gain potentiometer is used in “rheostat” (2-pin) configuration; this is the case with standard 3-pin potentiometers if the wiper is connected to one of the other terminals.
- The original gain potentiometer has a nominal value of 5k or 10k. Larger values are possible, but require other type of optocouplers. Please contact us with your requirements.
- The minimum resistance with the supplied NSL-32SR2 couplers is about 40 Ohms. Depending on your preamp model, this may limit the range of gain adjustment which can be achieved (in case of ADA8000, the gain range which can be remoted is from +10dB to +50dB; vs. the original range of +10dB to +60dB. This is rarely a problem as most preamps produce a significant amount of noise in the high gain ranges).
- Some preamps use stereo (or even more channel) potentiometers for gain control. It is possible to mod such models by adding additional optocouplers in series configuration, but you may need to swap the voltage regulator inside the RGC-24A-M to compensate the higher forward voltage of the coupler's LEDs. Please contact us for details.

7.4. Matching the control curve to your preamp

The remote gain controller is a precision, low-noise current source which controls the optocouplers light sources (LEDs). It delivers a controlled current in the range of 0 ... 25mA, adjustable in 10bit precision (1024 linear steps, or about 24 μ A/step). Because gain control is usually done using a log taper potentiometer, and also the optocoupler has a log control characteristic, one must emulate logarithmic behavior of “gain” vs. “output current” by software. This results in control curves are usually flat at the lower gain ranges (only a few bits per step), but very steep at the higher gains.

7.5. Reset to Factory Defaults

CAUTION: Resetting to Factory Defaults causes loss of all user-defined curves and parameters which were altered using SYSEX commands!

To restore the factory defaults, perform the following steps:

- Remove power from the RGC
- Hold down “ACTIVE” button while re-connecting power
- Continue to hold down the button until the yellow “ACTIVE” LED flashes three times

The factory defaults are now restored.

8. SPECIFICATIONS

Parameter	Value
Optocoupler outputs	0...25mA precision current sink, common anode Pinout: 1: Common anode 2: Cathode CH2 3: Cathode CH4 4: Cathode CH6 5: Cathode CH8 6: Cathode CH1 7: Cathode CH3 8: Cathode CH5 9: Cathode CH7
Standard control characteristics	Curve #1: 5k neg. log Curve #2: 25k neg. log Curve #3: unused Curve #4: Digital switching via reed relays There are lots of other possibilities (dual potentiometers , other curves and couplers etc.). Please contact us with your requirements.
Curve adjustment	17 nodes, intermediate values are interpolated
Power supply	8...12V DC, 1A Plug: OD=5.5mm, ID=2.5mm, center positive
Operating temperature	0...50°C
Storage temperature	0...70°C, non-condensing
Dimensions	LxBxH: 119x118.5x34 mm Mounting holes: 109.5x104.7mm
Weight	298 g

9. APPENDIX

9.1. Warranty

We offer a full two (2) year warranty from the date of purchase. Within this period, we repair or exchange your device free of charge in case of any defect.*

If you experience any problems, please contact us first. We try hard to solve your problem as soon as possible - even after the warranty period.

* Not covered by the warranty are any damages resulting out of improper use, willful damage, normal wear-out (especially of the connectors) or connection with incompatible devices (including, but not limited to, Ethernet equipment and third-party power supplies).

9.2. Contact

Appsys ProAudio
Rolf Eichenseher
Bullingerstr. 63 / BK241
CH-8004 Zürich
Switzerland

www.appsys.ch
info@appsys.ch
Phone: +41 22 550 05 42
Mobile: +41 76 747 07 42

9.3. Recycling



According to EU directive 2002/96/EU, electronic devices with a crossed-out dustbin may not be disposed into normal domestic waste.

Please return the products back for environment-friendly recycling, we'll refund you the shipping fees.

9.4. About this document

Behringer® is a registered Trademark of Behringer Corp.
Audiohm® is a registered Trademark of Silonex, Inc.

All information provided here is subject to change without prior notice.
Document Revision: 3
2011-08-24
Copyright © 2011 Appsys ProAudio

Printed in Switzerland